

**Wall Mount Flange Up**  
Part Number: WMCU-K47

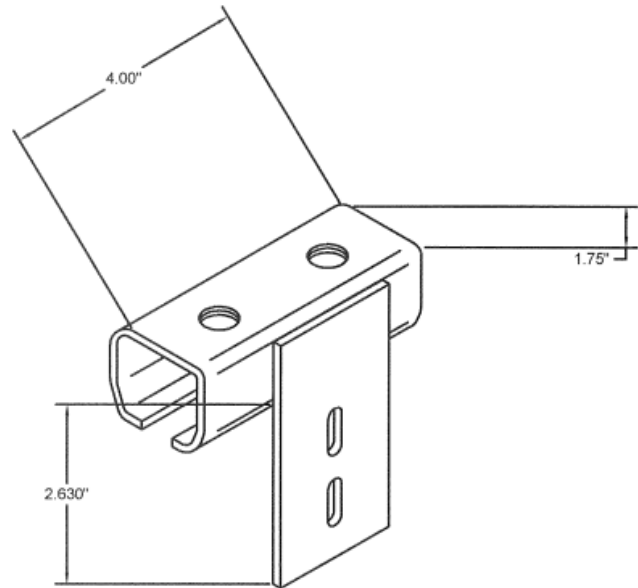

**Wall Mount Flange Down**  
Part Number: WMCD-K46

## Details

MATERIALS	Pre galvanized G-60 or better
WELDED AREAS	Commercial clear zinc plated
TRACK MATERIAL	16 Gauge commercial quality low carbon steel

## Description

Splices and mounting hardware 10 gauge commercial quality low carbon steel.

The charts below illustrate track capacity for various support spacings. The curves represent loads evenly distributed between supports (left) and loads concentrated at the center of the span (right). Interpolate between these two curves when the total load can be bunched together and is not long enough to fill the space between the supports.

Curves on the chart represent the track loaded at 15,000 psi maximum stress. Since yield stress for the low carbon steel track is 30,000 psi, the factor of safety at these loads is 2:1. The factor of safety compared to ultimate tensile strength is 3:1.

For hazardous applications where these factors of safety are inadequate, multiply the actual loads by compensating factors before using the charts. High elevation above the floor or the presence of the catwalk or other maintenance area near the track system might qualify for a more conservative design.

**16RT LOAD DEFLECTION CHART LOAD EVENLY  
DISTRIBUTED BETWEEN SUPPORTS**

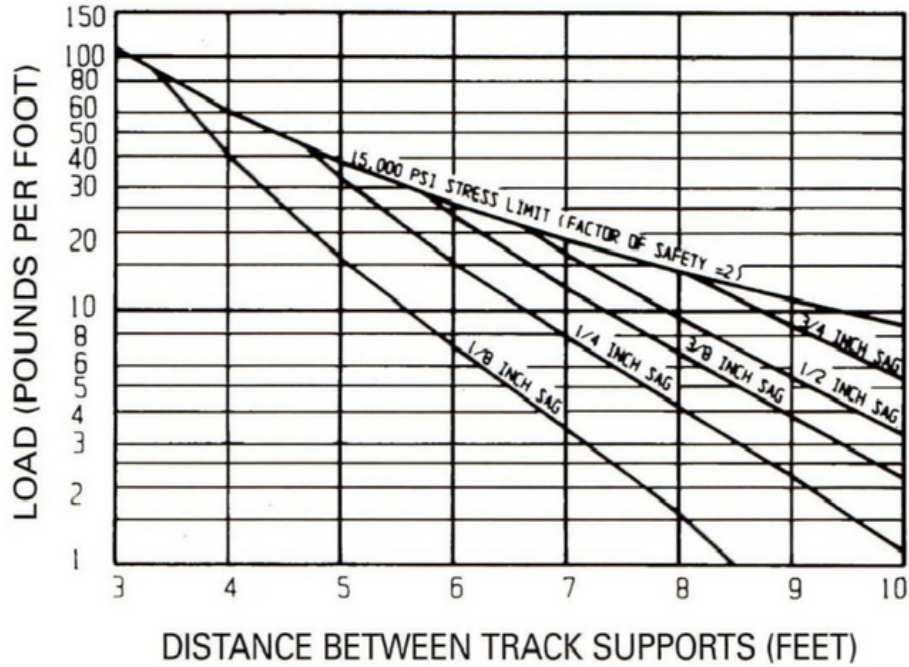

**16RT LOAD DEFLECTION CHART ENTIRE LOAD AT  
ONE POINT MIDWAY BETWEEN SUPPORTS**

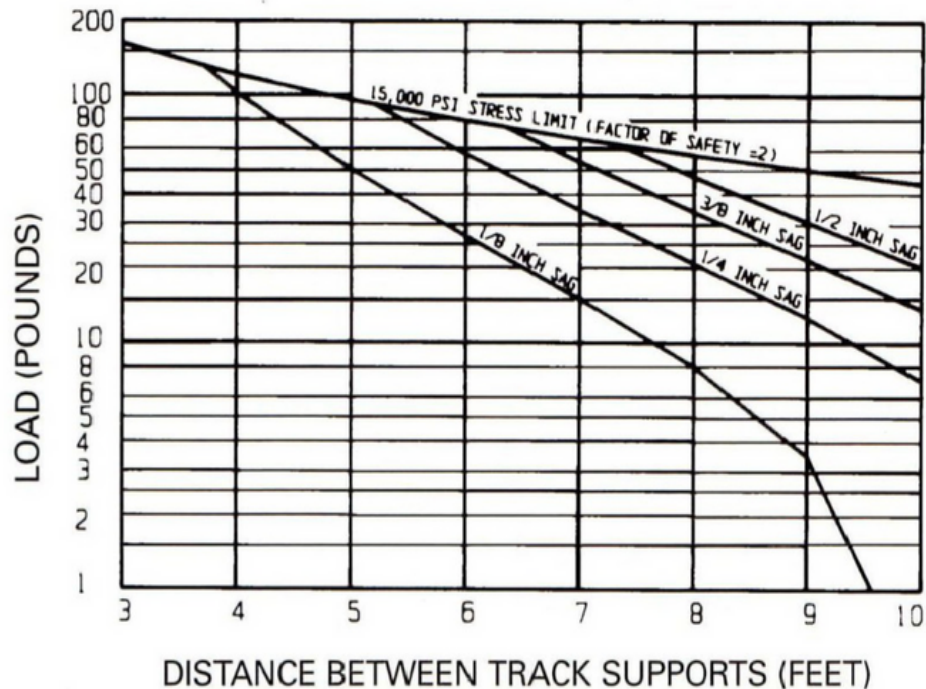

Our technical sales representatives will assist you with your project requirements.  
Give us a call today at **847-439-4565** for a quote!

